

# Fokker T.V Czech Master Kits<sup>1</sup> resin kit

## Monoplane bomber

Scale 1:72

The Fokker T.V was originally conceived as a heavily armed “air cruiser”, intended to ensure air superiority in the Dutch air space. It was, however, fast superseded by more performing fighters, and has operationally been used as a bomber by the Dutch Army ML (Military Air Department), which ordered 16 aircraft. Fokker had hoped to sell the aircraft also to the Royal Dutch East-Indies Army Air Department (KNIL LA), but they preferred to buy all-metal Glenn Martin bomber, even if these had inferior performance. [<find better quality pictures>](#)

The T.V made its maiden flight October 10, 1937 with Dutch military insignia, but received its registration “850” and its armament only later, when ready for demonstration flights.

The nine operational T.V’s saw several sorties during the short, four day operations in May 1940, mainly to

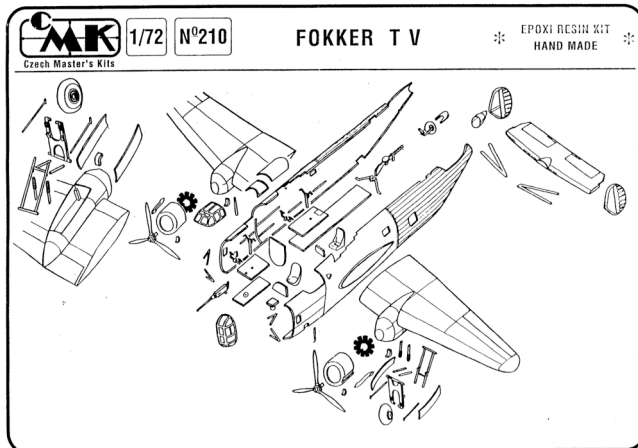
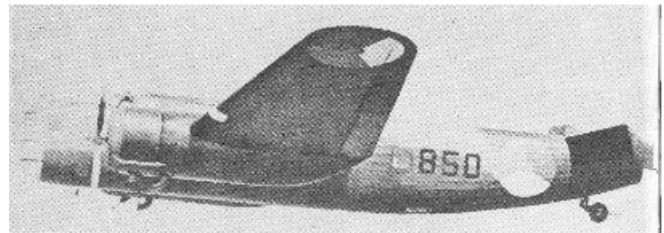
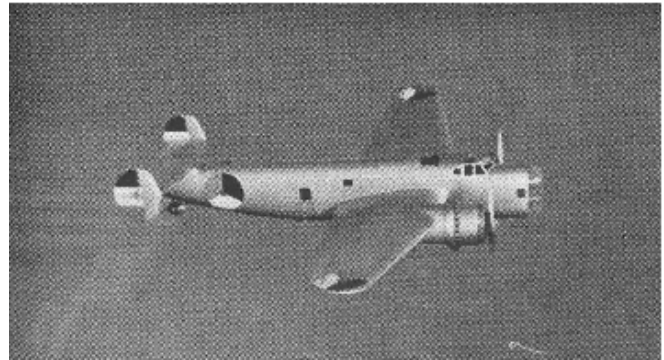

bomb airfields and bridges and attacking ground troops to slow down the German progress.

The kit comes in a plastic bag and contains the resin parts, clear vacuum formed plastic parts for the nose, tail cone and cockpit windows . No decals are included in the kit, but luckily I still have the decals of the T.V kit of Aviation USK<sup>2</sup>.

The instruction sheet is consists only of the A5 sheet of paper serving as “cover” in the plastic bag, and shows an exploded view indicating approximately where all parts should go. Painting instructions are missing.

Alting (ref.1), Arnken (ref.2), Franquinet (ref. 3), Hegener (ref. 4), Hooftman (ref. 5 and 6), Schoenmaker (ref. 7), Wesselink (ref. 8), Vliegwereld (ref. 9), Gerdessen (ref. 10), Postma (ref. 11) and Casius (ref. 12) report the dimensions of the Fokker T.V, while Hegener, Hooftman (ref. 5) and Gerdessen also include a three-view drawing of the aircraft.

	<i>Ref.</i>	<i>1:72</i>	<i>model</i>
<i>Span</i>	20.76-21.00 m	288.3-291.7 mm	mm
<i>Length</i>	15.60-16.15 m	216.7-224.3 mm	mm
<i>Height</i>	4.20-5.06 m	58.3-70.3 mm	mm
<i>Engine</i>	Bristol Pegasus XXVI; 2 x 915-920 hp		
<i>Crew</i>	5		
<i>Armament</i>	1 Solothurn 20 mm cannon; 4 movable Lewis 7.9 mm machine guns; 1000 kg bombs		

### General

<text>

### Cockpit

<text>

### Fuselage

<text>

**Wing**

&lt;text&gt;

**Undercarriage**

&lt;text&gt;

**Final assembly**

&lt;text&gt;

**References**

1. P. Alting, *Fokkers in Uniform, Driekwart eeuw militaire Fokker vliegtuigen*, pp. 48, 62, Rebo Producties, Sassenheim, 1988
2. R.A. Arnken, *De Ontwikkeling van het Vliegtuig*, pp. 211, 223, Gottmer, Haarlem, 1946
3. E. Franquinet, *Fokker, Een leven voor de luchtvaart*, p. 328, N.V. Uitgeversmaatschappij "De Pelgrim", Eindhoven, 1946
4. H. Hegener, *Fokker, The Man and the Aircraft*, pp. 92, 164-165, 206, ISBN 0-8168-6370-9, 1961
5. H. Hooftman, *Nederlandse Vliegtuig Encyclopedie, Fokker T-V en T-IX*, all pages, pp. 3, 100-102 and 119 for three-view drawing; Cockpit-Uitgeverij, Bennekom, 1979
6. H. Hooftman, *Van Brik tot Starfighter, Deel I: Met stofbril en leren vliegkap*, pp. 164, 171-175, La Rivière & Voorhoeve, Zwolle, 1962
7. W. Schoemaker & T. Postma, *Klu Vliegtuigen, De vliegtuigen van de Koninklijke Luchtmacht vanaf 1913*, pp. 20, 62-64, ISBN 90 6013 966 6, 1987
8. T. Wesselink & T. Postma, *De Nederlandse Vliegtuigen, Alle vliegtuigen ooit in Nederland ontworpen en gebouwd*, pp. 109-110, Unieboek B.V., Bussum, 1982
9. Vliegwereld, *Het Dertigjarige Bestaan van de Nederlandse Fokkerfabriek 1929 – 1949*, pp. 470, 479, Jaargang 15, No. 29, 1949
10. F. Gerdessen & L. Boerman, *Fokker T.V 'Luchtkruiser', History, camouflage and markings*, pp. 27-30, 50, 56, ISBN 978-94-90092-01-6, 2009
11. T. Postma, *Vermetelete vliegende Hollanders*, pp. 43, 64, 76, 83, ISBN 90 228 3987 7, De Haan, Bussum, 1975
12. G. Casius & T. Postma, *40 Jaar Luchtvaart in Indië, De geschiedenis van de luchtvaart in Nederlands-Indië in de periode 1920-1950*, p. 51, ISBN 90-6013-944-5, ????
13. P. Alting, *Van Spin tot Fokker 100*, pp. 46, 48, Rebo Producties, Sassenheim, 1988
14. K. van de Berg, R. Hezemans & E. Koolhaas, *Van Luchtvaartafdeling tot Koninklijke Luchtmacht, 75 jaar militaire luchtvaart in Nederland*, p. 22, Rebo Producties, Sassenheim, 1988
15. F. Gerdessen & L. Boerman, *Fokker D.XXI, History, camouflage and markings*, pp. 21, 41, Dutch Decal, Zwammerdam, 2007
16. H. Hooftman, *Fokker, Bekende en onbekende vliegtuigtypes van A.H.G. Fokker, Neerlands grootste vliegtuigbouwer*, pp. 40-41, ARTI beeld encyclopedie 36, Alkmaar, 1959
17. H. Hooftman, *Nederlandse Vliegtuig Encyclopedie, Fokker G-I*, p. 17, Cockpit-Uitgeverij, Bennekom, 1977
18. J. van Huijstee, *Vervlogen jaren van Fokker*, p. 41, Van Soeren & Co, Amsterdam, 1997
19. T. Postma, *Fameuze Fokker Vliegtuigen*, pp. 53-54, Luchtvaart in Beeld nr. 1, Omniboek, Kampen, 1978
20. T. Postma, *Fokker, Bouwer aan de Wereldluchtvaart*, pp. 1, 10, 106, 109-110, Fibula - Van Dishoeck, Haarlem, 1979
21. W. Vredeling, *Fokker D.23*, p. 66, Geronomy bv, Maarssen, 2007
22. F. Troost, S. van der Zee & W. van Zoetendaal, *Salto Mortale - Fokker in bedrijf 1911-1996*, pp. 174, 185, ISBN 907557410X, 1998
23. W.C.J. Westerop, *Fokker en de twintigste eeuw: een historische relatie*, pp. 32, 37, ISBN 90-9011870-5, 1998
24. T. Postma, *De F-16 en zijn voorgangers, Luchtvaart in beeld nr. 4*, p. 77, ISBN 90 620 7328 x, 1978

<sup>1</sup> www.xxx.yy

<sup>2</sup> See the building report.